



ACTIVE MAPPING: RESISTING NIDS EVASION WITHOUT ALTERING TRAFFIC

**Umesh Shankar and Vern Paxson
UC Berkeley and ICSI**

AUTOMATIC GENERATION AND ANAYLSIS OF NIDS ATTACKS

**Shai Rubin, Somesh Jha, and Barton Miller
UW Madison**

(Presented today in class by Justine!)

THREE PROBLEMS

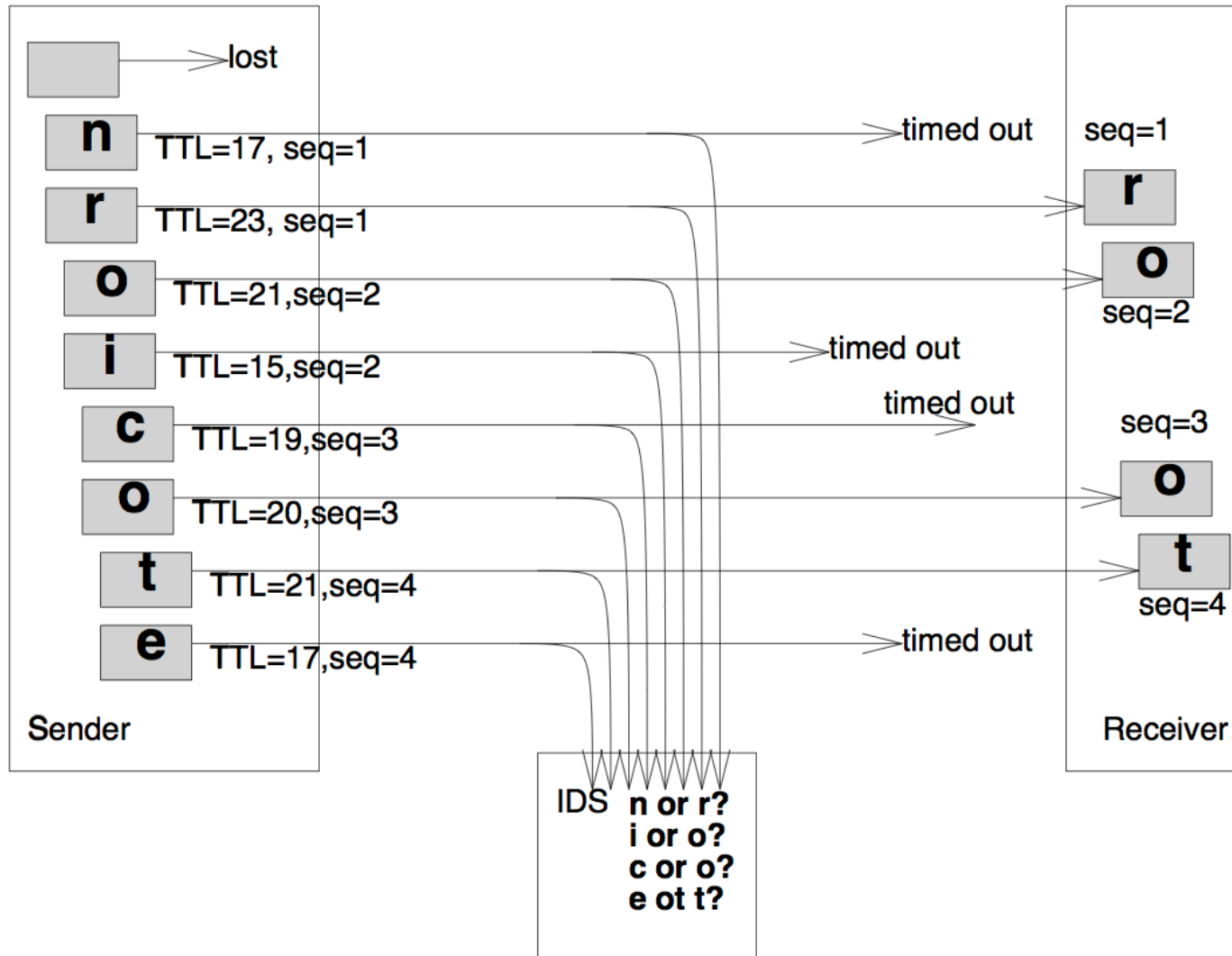

HANDLEY, PAXSON AND KREIBICH: FIX #2 AND #3 WITH A “NORMALIZER”

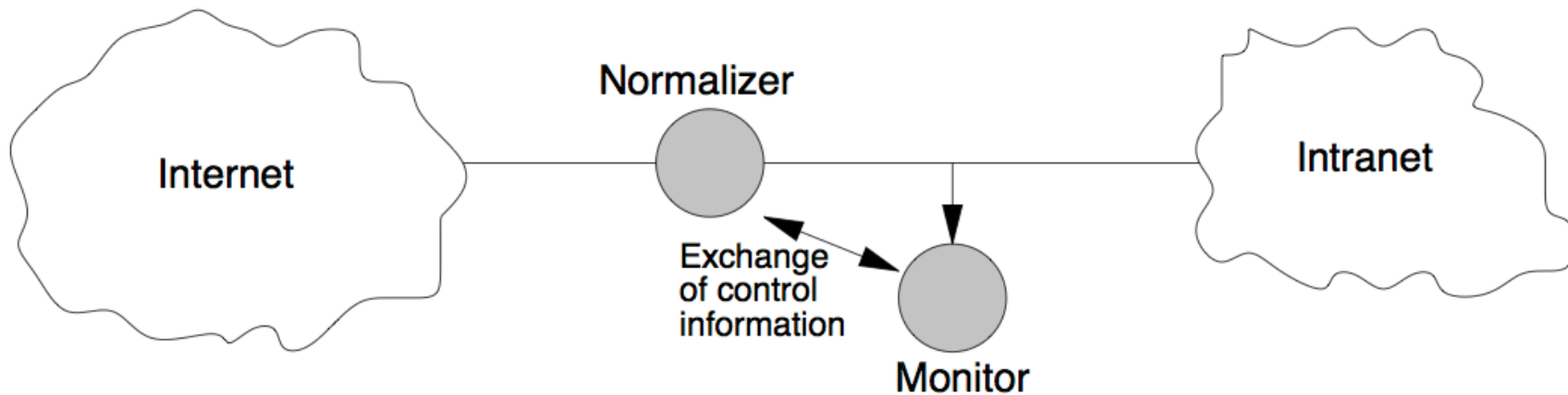

SHANKAR AND PAXSON REVISIT: DO WE REALLY NEED TO MODIFY PACKETS TO RESOLVE PROBLEMS #2 AND #3?

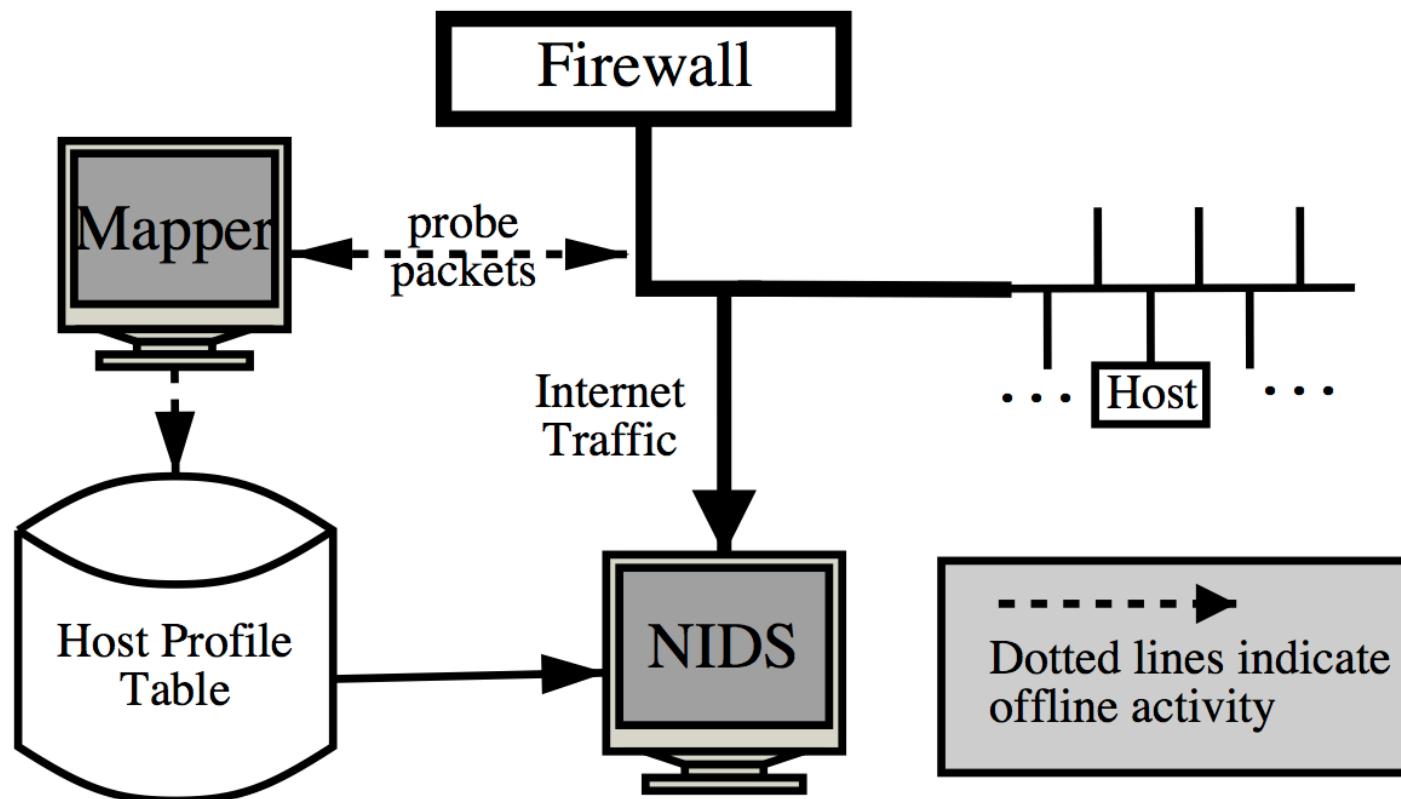

RUBIN & Co.: THOSE AREN'T THE ONLY WAYS TO EVADE A NIDS. PROTECTING AGAINST #1 IS HARDER THAN YOU THINK!

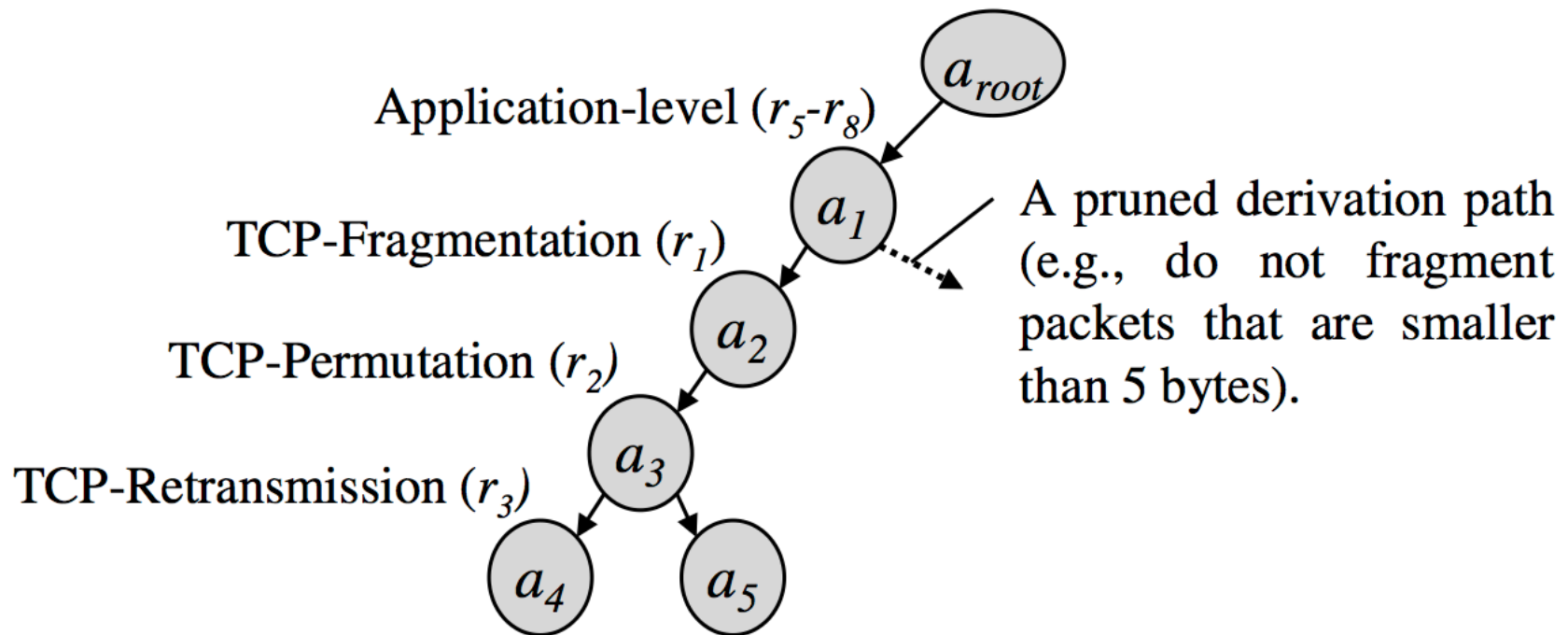

CONCLUSION

